

8 7 6 5 4 3 2 1

D
C
B
A

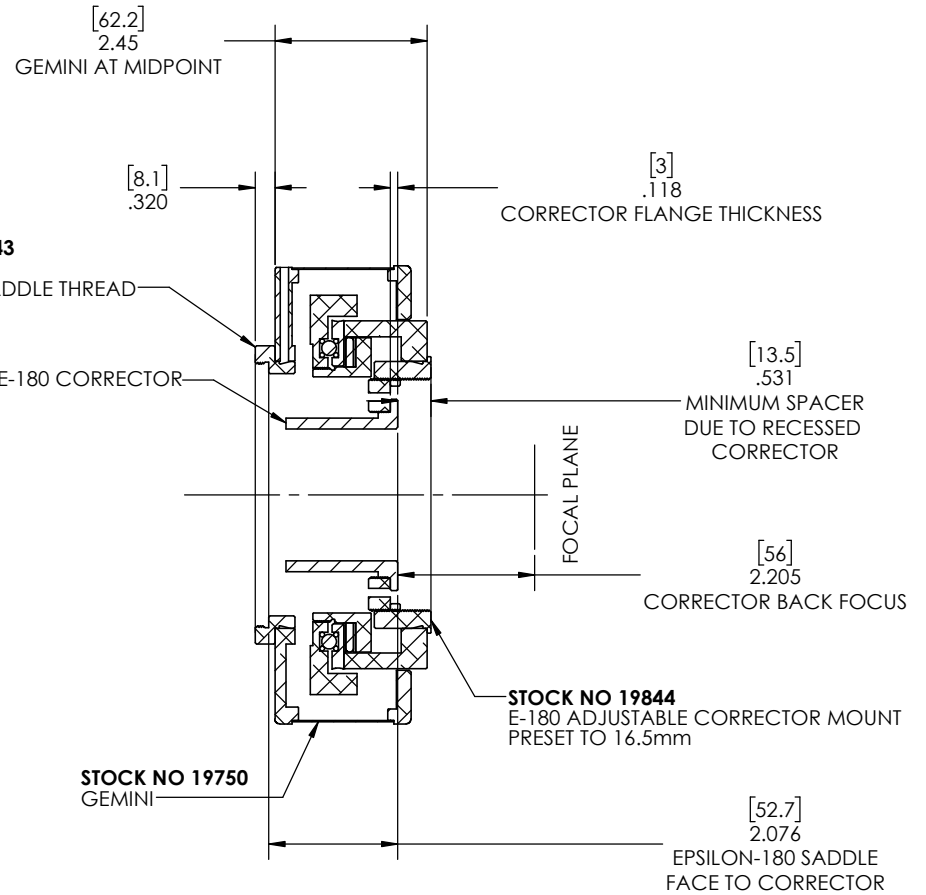
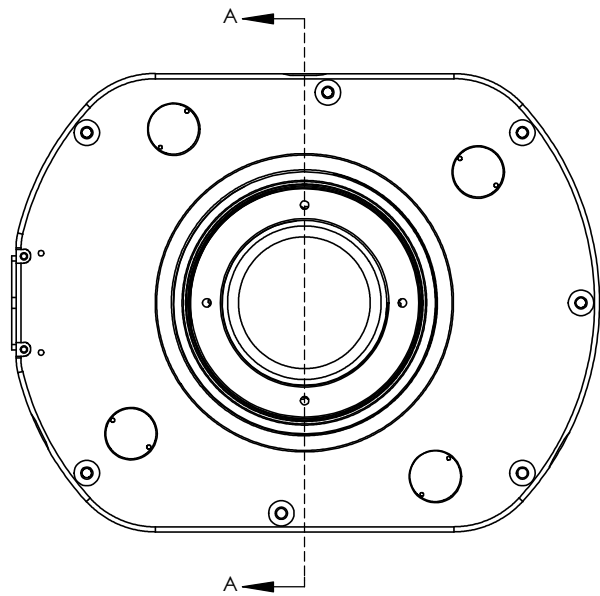

SECTION A-A

UNLESS OTHERWISE SPECIFIED: DIMENSIONS ARE IN INCHES TWO PLACE DECIMAL ±.007 THREE PLACE DECIMAL ±.003	DRAWN	NAME	DATE	Optec Inc.
	CHECKED	LD	12/9/19	
	ENG APPR.			
	MFG APPR.			
	Q.A.			
MATERIAL	CONTRACT			TITLE:
N/A	GEMINI			GEMINI WITH E-180
FINISH	SEE NOTES			SIZE
DO NOT SCALE DRAWING				B
				DWG. NO.
				SCALE: 1:2
				WEIGHT:
				SHEET 1 OF 1

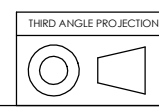

8 7 6 5 4 3 2 1