

8 7 6 5 4 3 2 1

D
C
B
A

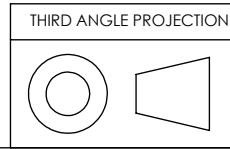
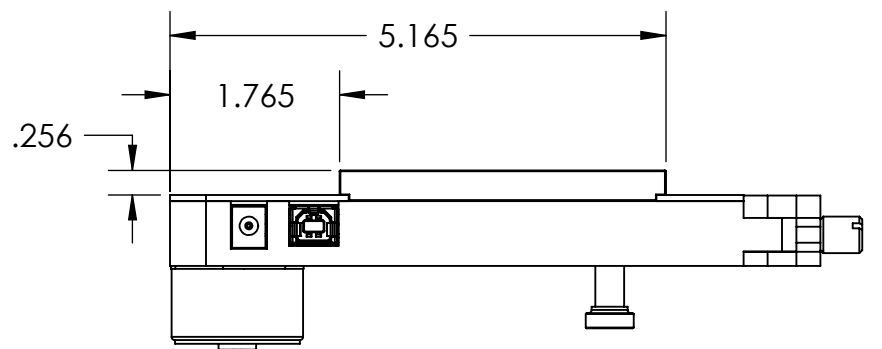
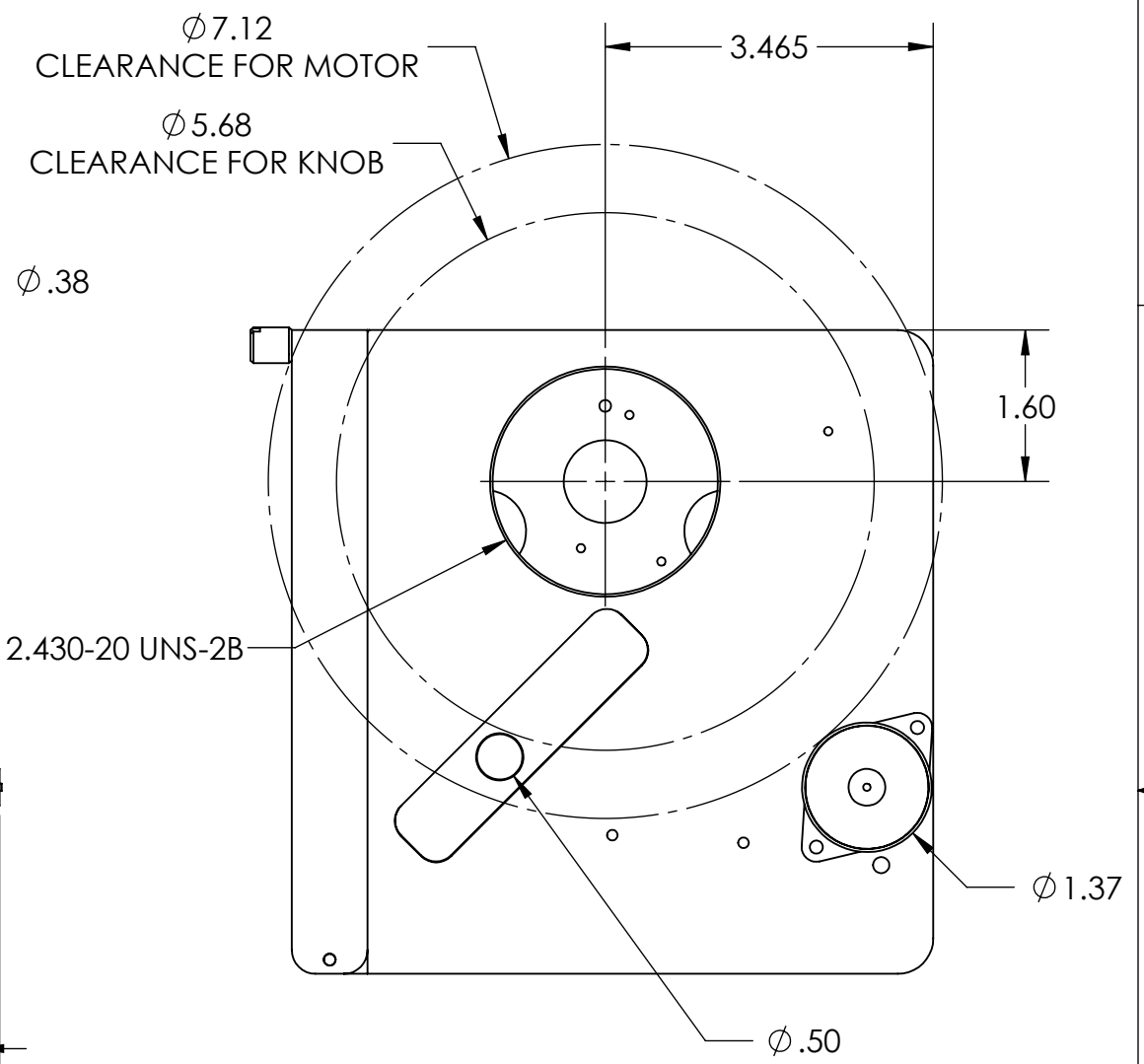
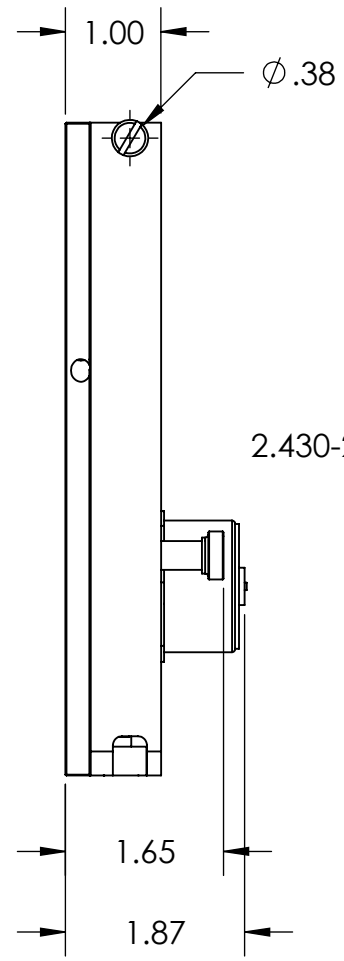
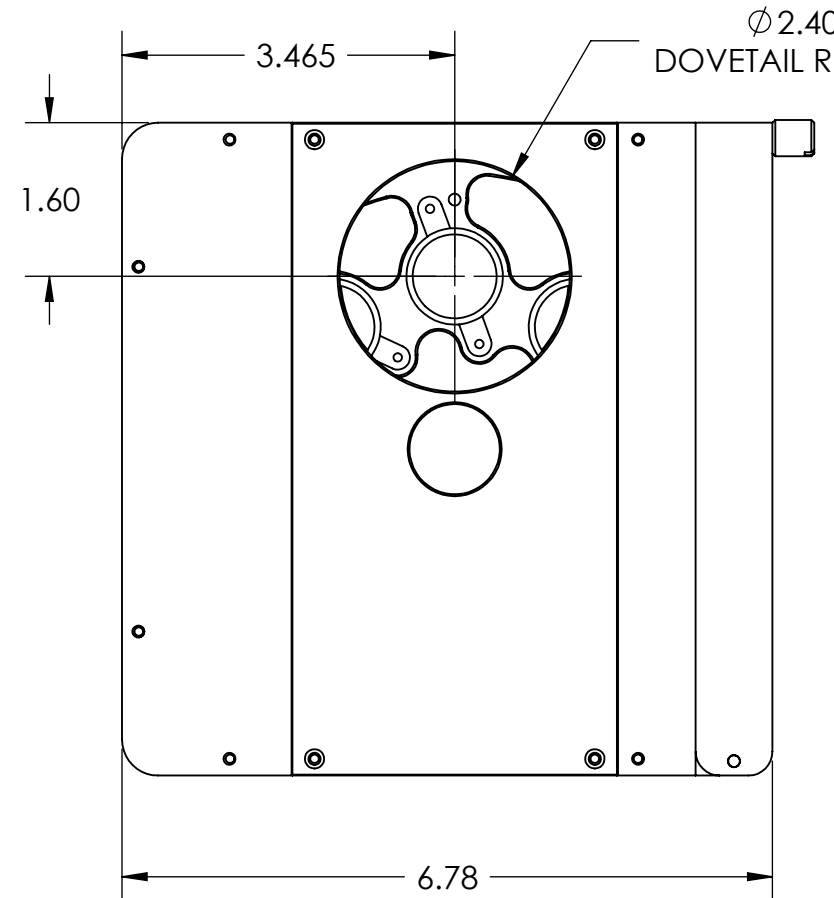
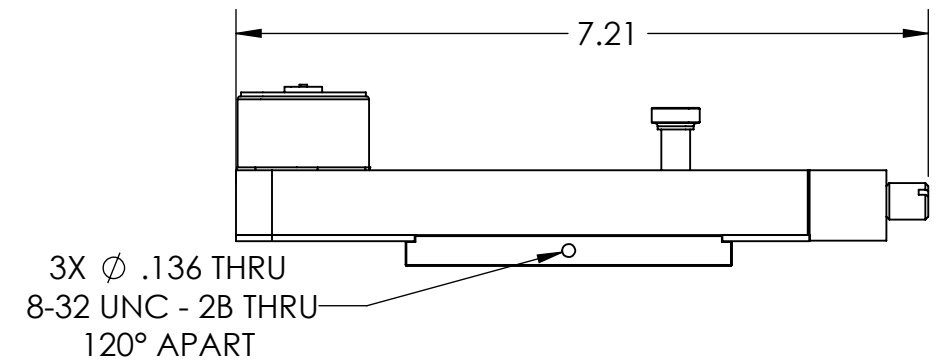
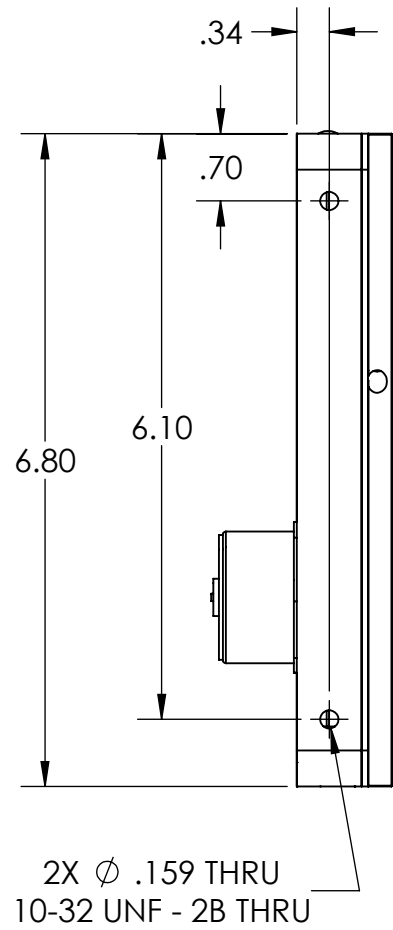

UNLESS OTHERWISE SPECIFIED: DIMENSIONS ARE IN INCHES TOLERANCES: FRACTIONAL ± ANGULAR: MACH ± BEND ± TWO PLACE DECIMAL ±.007 THREE PLACE DECIMAL ±.003	DRAWN	NAME	DATE	Optec Inc. TITLE: HSFW ASSEMBLY
	CHECKED	LD	8/27/12	
	ENG APPR.			
	MFG APPR.			
MATERIAL	CONTRACT			SIZE DWG. NO. B 17-06450
FINISH	HSFW			
DO NOT SCALE DRAWING	SCALE: 1:2		WEIGHT:	SHEET 1 OF 1

8 7 6 5 4 3 2 1