

PN 4847
 STK NO 17821

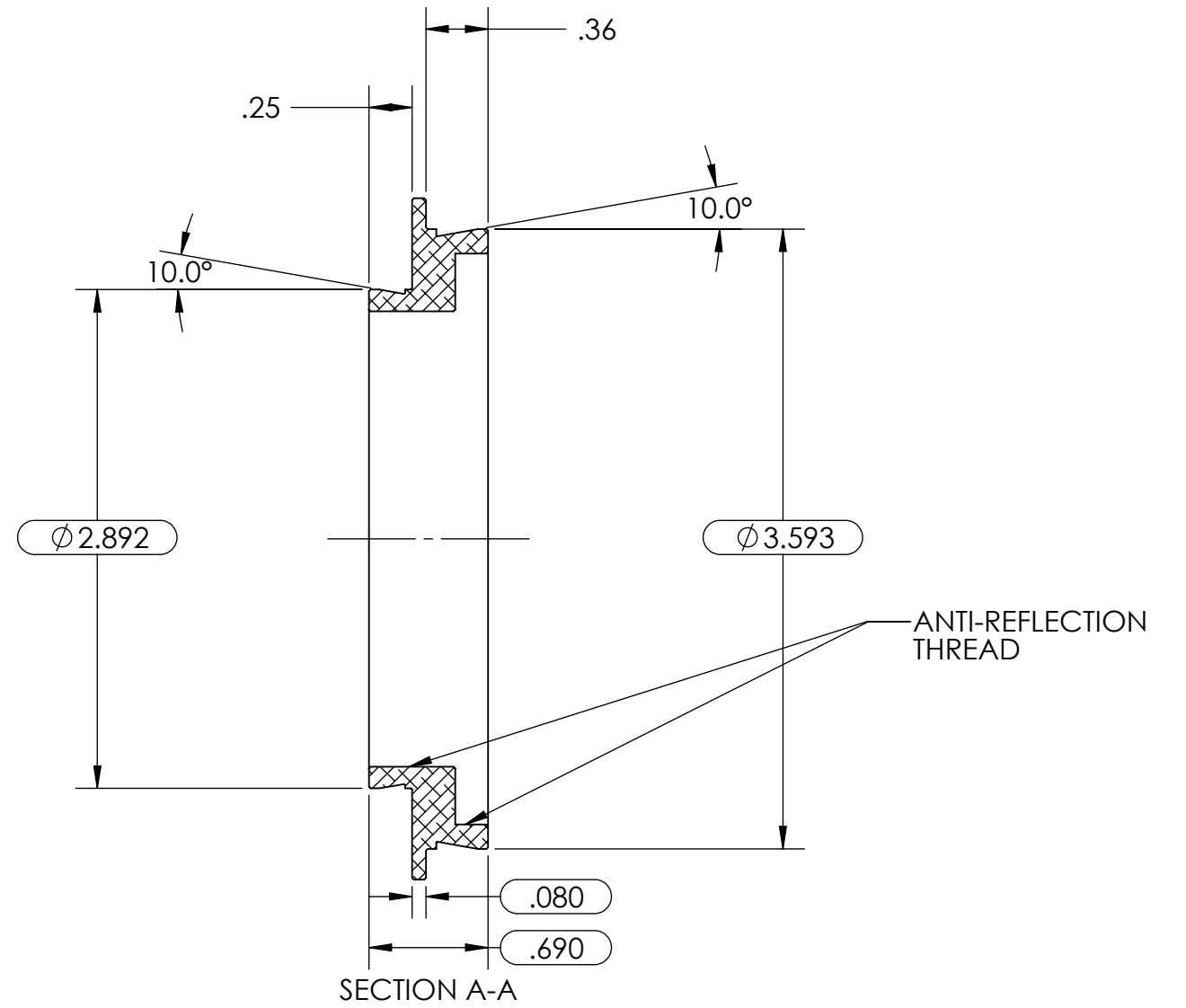
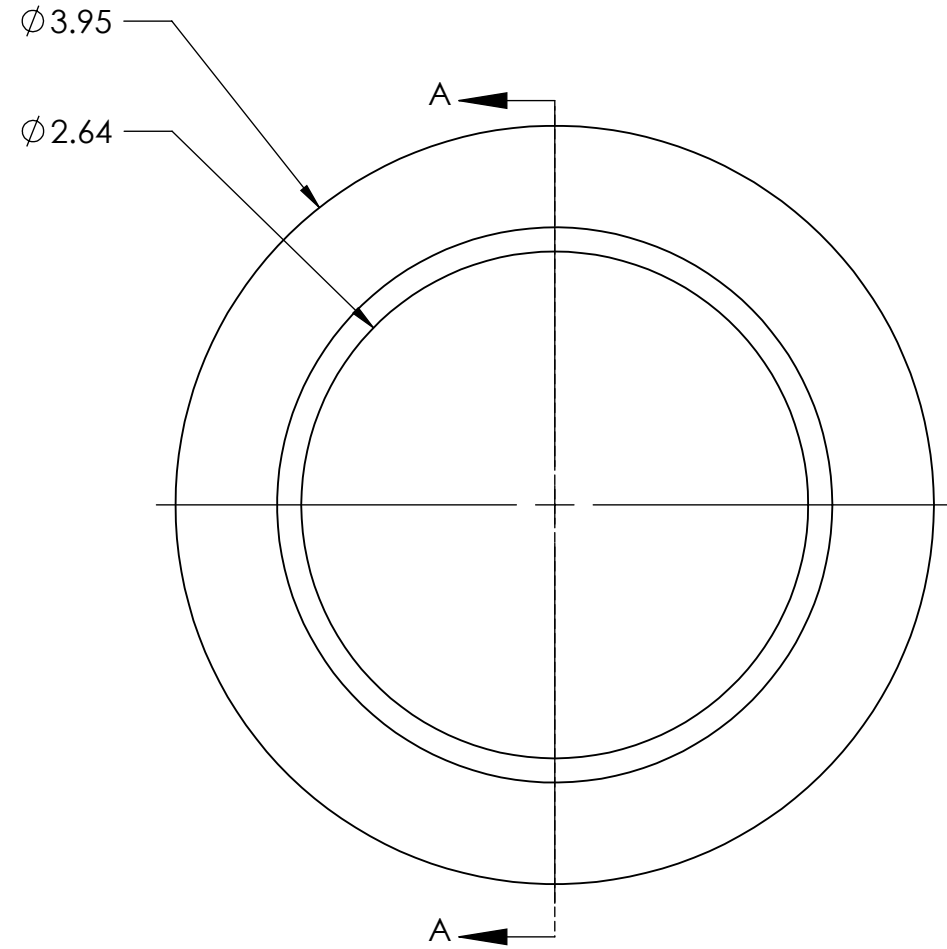

UNLESS OTHERWISE SPECIFIED: DIMENSIONS ARE IN INCHES TOLERANCES: ANGULAR: ± 1 TWO PLACE DECIMAL $\pm .003$ THREE PLACE DECIMAL $\pm .007$	DRAWN	LD	DATE	Optec Inc.		
	CHECKED					TITLE:
	ENG APPR.			VSI 2.9" TO 3600		
	MFG APPR.					
MATERIAL 6061	Contract			SIZE	DWG. NO.	REV
FINISH BRIGHTDIP FROSTKOTE BLACK	OPTEC-3600			B	17-06686	1.0
DO NOT SCALE DRAWING				SCALE: 1:1	WEIGHT:	SHEET 1 OF 1