

PN 7048
 STK. NO. 17851

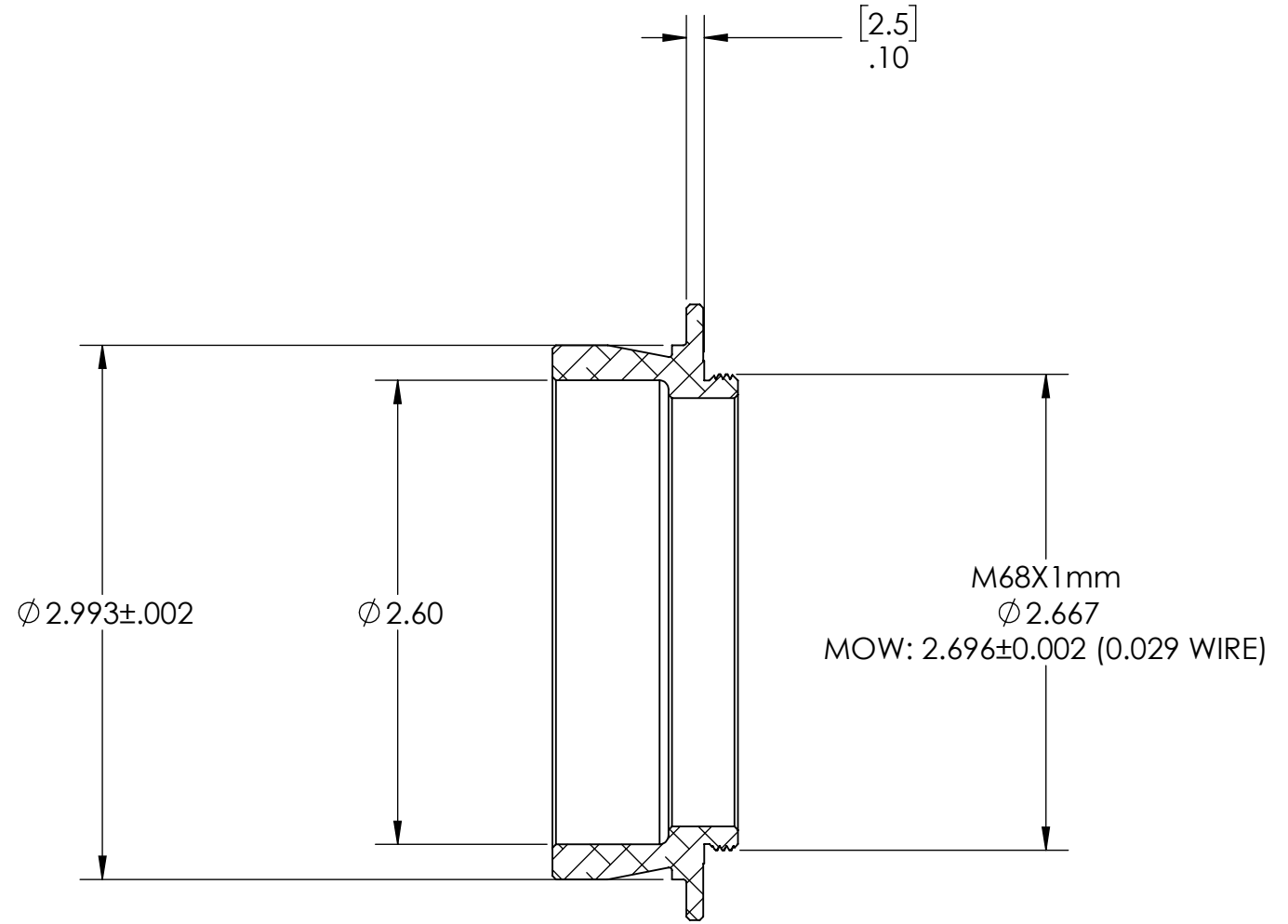

SECTION A-A

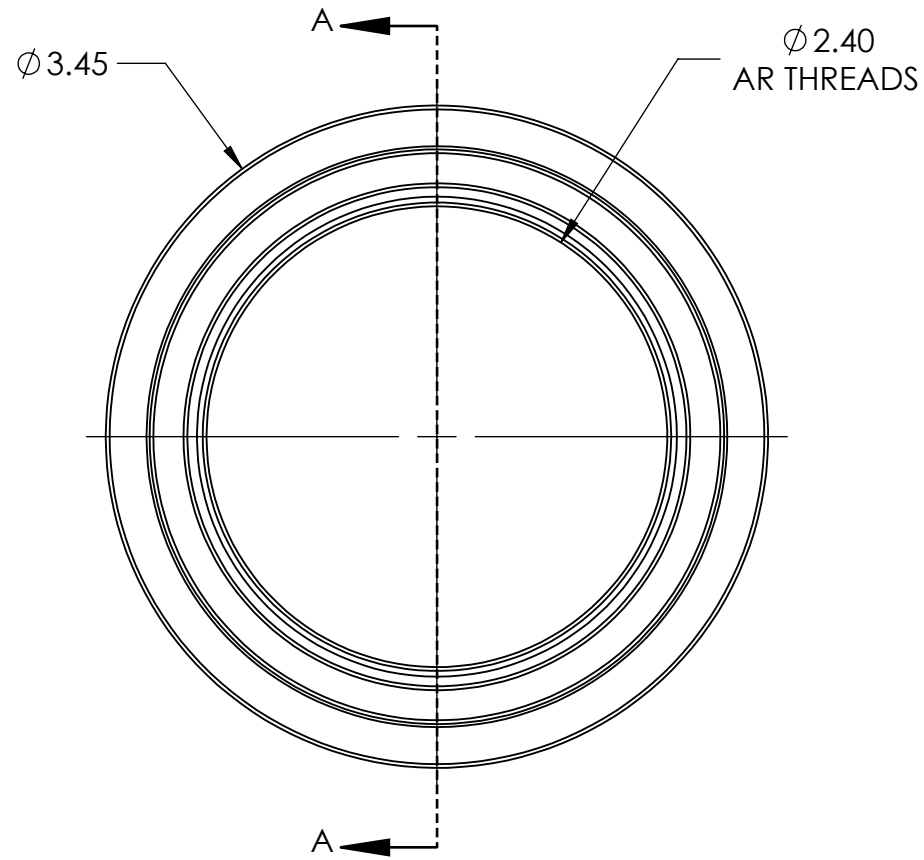
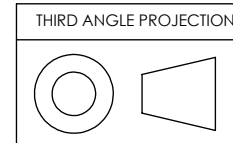

UNLESS OTHERWISE SPECIFIED: DIMENSIONS ARE IN INCHES TWO PLACE DECIMAL ±.007 THREE PLACE DECIMAL ±.003	DRAWN	LD	02/09/21	Optec Inc.	
	CHECKED				TITLE: 3-INCH TO M68X1mm
	ENG APPR.				
	MFG APPR.				
MATERIAL 6061-T6	CONTRACT			SIZE DWG. NO. B 19-06723	
FINISH SEE NOTES	3-INCH ADAPTERS				
DO NOT SCALE DRAWING	SCALE: 1:1		WEIGHT:	SHEET 1 OF 1	