

PN 5945
 STK NO. 17846

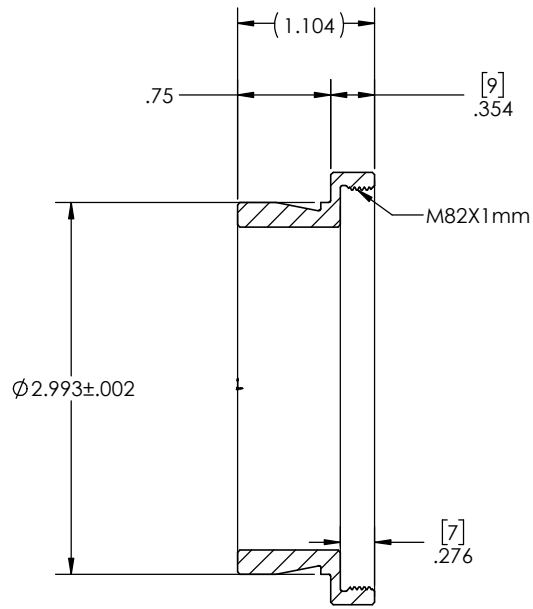

SECTION A-A

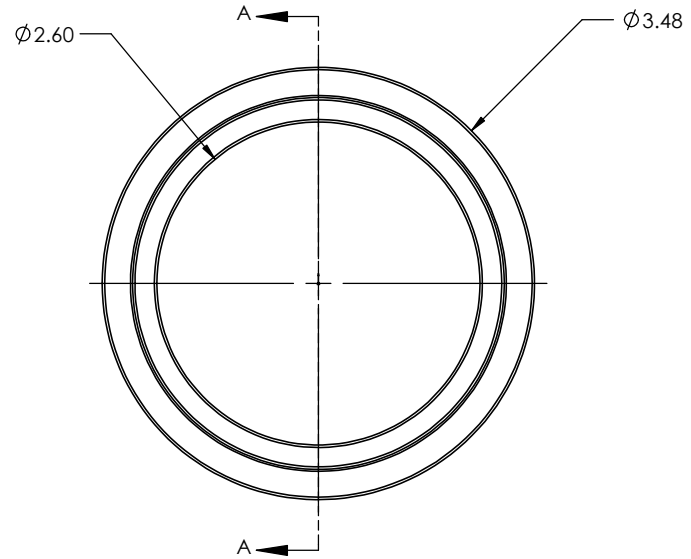

THIRD ANGLE PROJECTION



| | | | | |
|---|-----------|-----------------|--------|--|
| UNLESS OTHERWISE SPECIFIED: DIMENSIONS ARE IN INCHES TWO PLACE DECIMAL $\pm .007$ THREE PLACE DECIMAL $\pm .003$ | DRAWN | NAME | DATE | Optec Inc. TITLE: 3-INCH DOVETAIL TO M82X1mm |
| | CHECKED | LD | 2/5/18 | |
| | ENG APPR. | | | |
| | MFG APPR. | | | |
| MATERIAL | 6061-T6 | CONTRACT | | SIZE DWG. NO. |
| FINISH | SEE NOTES | 3-INCH ADAPTERS | | B 19-06708 |
| DO NOT SCALE DRAWING | | | | SCALE: 1:1 WEIGHT: SHEET 1 OF 1 |