

PN 5902  
 STK. NO. 17844

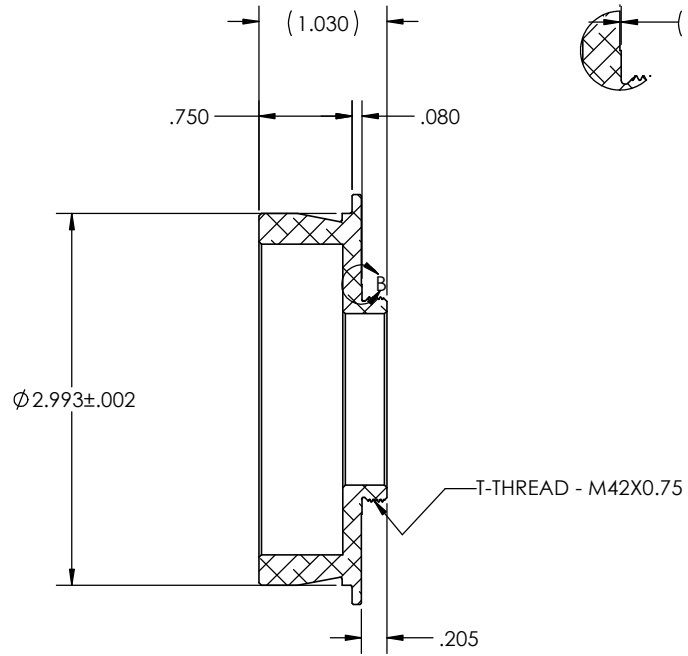

SECTION A-A

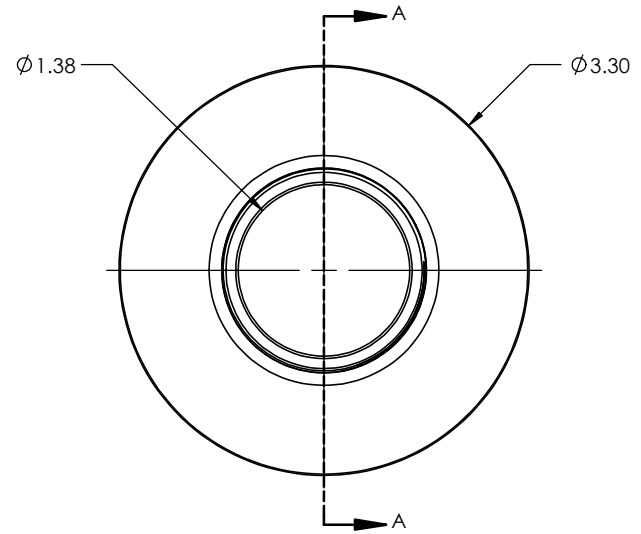

THIRD ANGLE PROJECTION



UNLESS OTHERWISE SPECIFIED: DIMENSIONS ARE IN INCHES TWO PLACE DECIMAL ±.007 THREE PLACE DECIMAL ±.003	DRAWN	NAME	DATE	<b>Optec Inc.</b> TITLE: 3-INCH TO T-THREAD
	CHECKED	LD	7/17/17	
	ENG APPR.			
	MFG APPR.			
MATERIAL	6061-T6	CONTRACT		SIZE DWG. NO. <b>B</b> 17-06709
FINISH	SEE NOTES	3-INCH ADAPTERS		SCALE: 1:1 WEIGHT:
DO NOT SCALE DRAWING				SHEET 1 OF 1