

PN 5534  
STK NO 17839

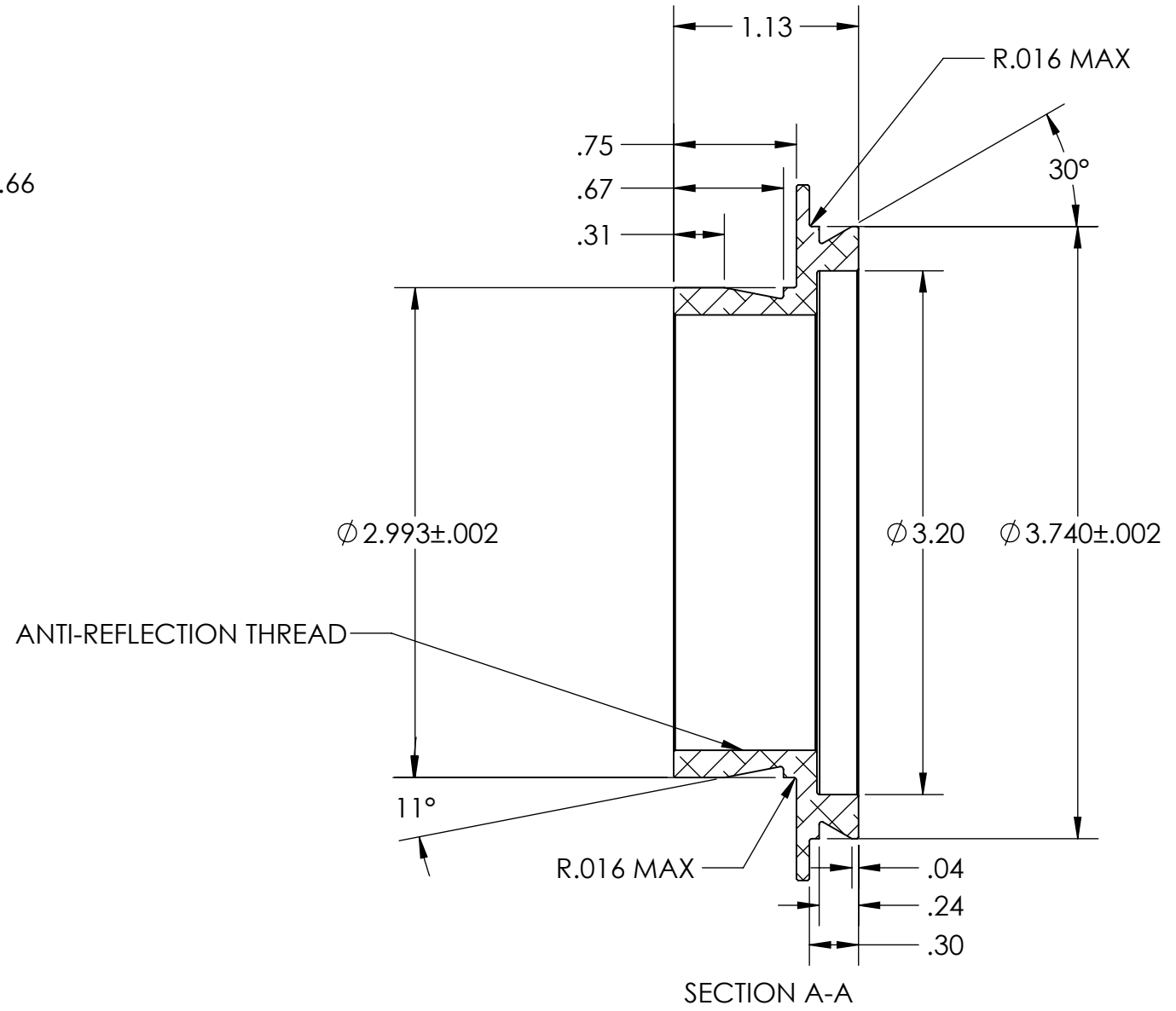

| REVISIONS |      |                 |            |          |
|-----------|------|-----------------|------------|----------|
| ZONE      | REV. | DESCRIPTION     | DATE       | APPROVED |
|           | A    | INITIAL RELEASE | 12/19/2011 | LD       |

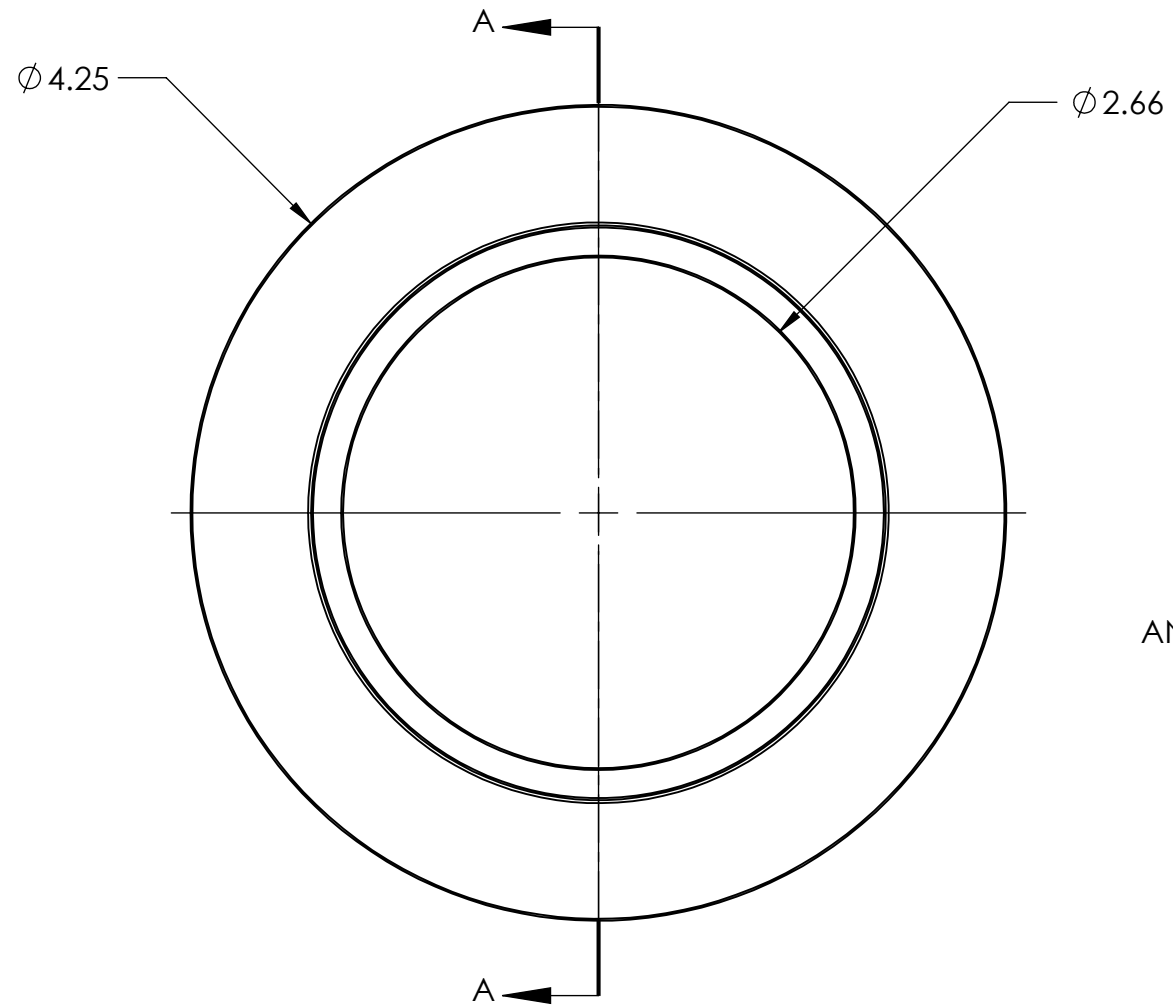
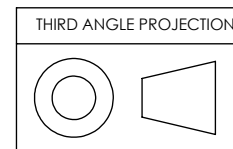

|                             |  |                 |      |      |                                 |                                      |
|-----------------------------|--|-----------------|------|------|---------------------------------|--------------------------------------|
| UNLESS OTHERWISE SPECIFIED: |  | DRAWN           | NAME | DATE | <b>Optec Inc.</b>               |                                      |
| DIMENSIONS ARE IN INCHES    |  | CHECKED         |      |      |                                 | TITLE:<br><b>3-INCH TO FLI ATLAS</b> |
| TWO PLACE DECIMAL ±.007     |  | ENG APPR.       |      |      |                                 |                                      |
| THREE PLACE DECIMAL ±.003   |  | MFG APPR.       |      |      |                                 |                                      |
| MATERIAL: 6061-T6           |  | Q.A.            |      |      | SIZE DWG. NO.                   |                                      |
| STOCK SIZE:                 |  | CONTRACT        |      |      | <b>B</b> <b>19-06701</b>        |                                      |
| 0.00 X 0.00 X .00           |  | 3-INCH ADAPTERS |      |      | SCALE: 1:1 WEIGHT: SHEET 1 OF 1 |                                      |
| FINISH SEE NOTES            |  |                 |      |      |                                 |                                      |
| DO NOT SCALE DRAWING        |  |                 |      |      |                                 |                                      |