

8 7 6 5 4 3 2 1

D D

C C

B B

A A

8 7 6 5 4 3 2 1

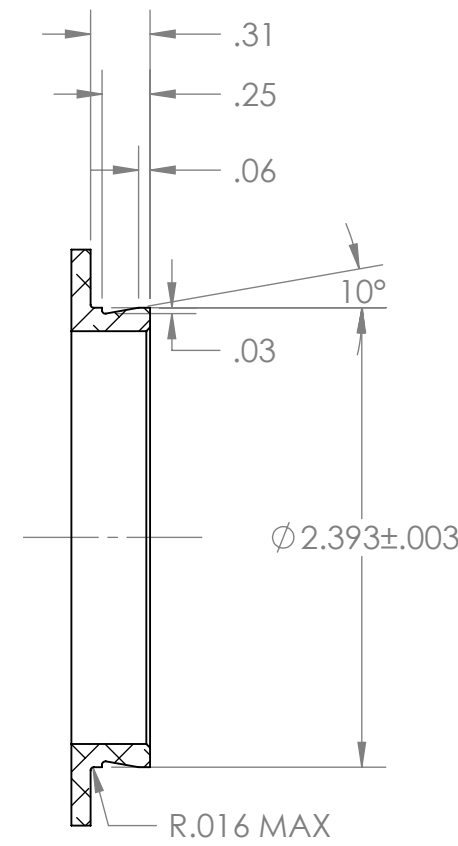

SECTION A-A

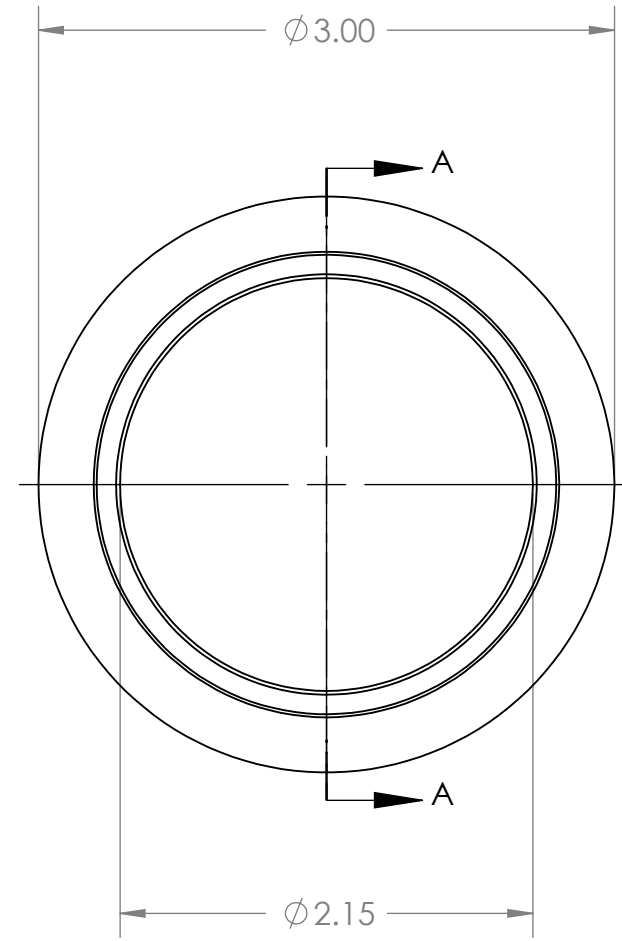

UNLESS OTHERWISE SPECIFIED: DIMENSIONS ARE IN INCHES TOLERANCES: FRACTIONAL ± ANGULAR: MACH ± BEND ± TWO PLACE DECIMAL ±.007 THREE PLACE DECIMAL ±.003	DRAWN	NAME	DATE	Optec, Inc.
	CHECKED	ELD	04/01/09	
	ENG APPR.			
	MFG APPR.			
MATERIAL	CONTRACT			TITLE: OPTEC-2400 DOVETAILED
6061-T6	DOVETAILED			
FINISH				SIZE
FROSTKOTE BRIGHT DIP BLACK	B	17-99001		
DO NOT SCALE DRAWING	SCALE: 1:1	WEIGHT:	SHEET 1 OF 1	

