

PN 4895  
STK NO 17666

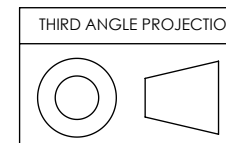
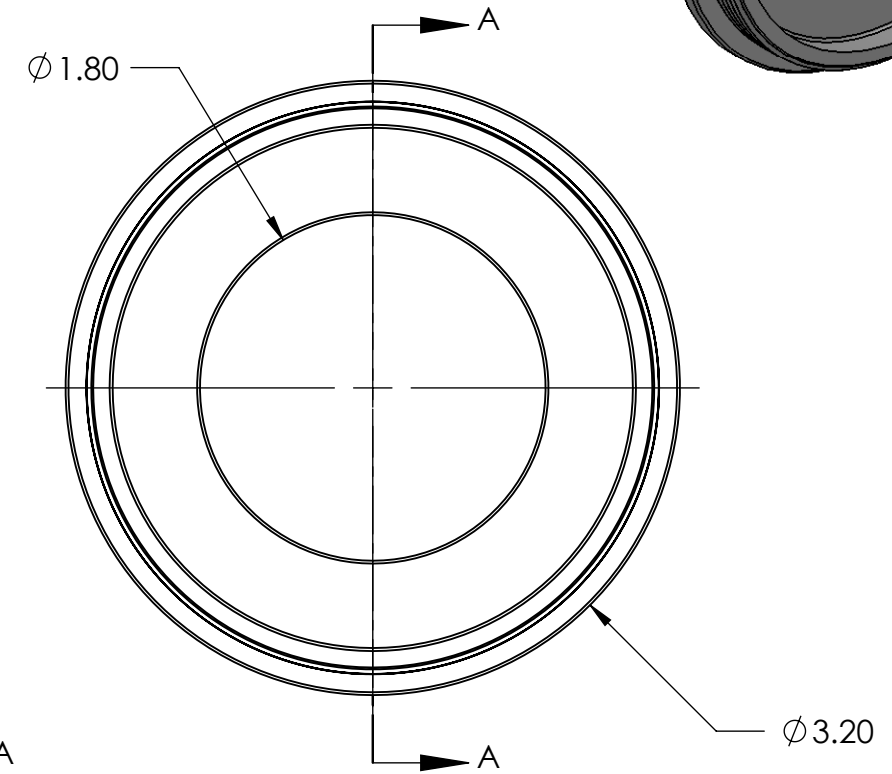
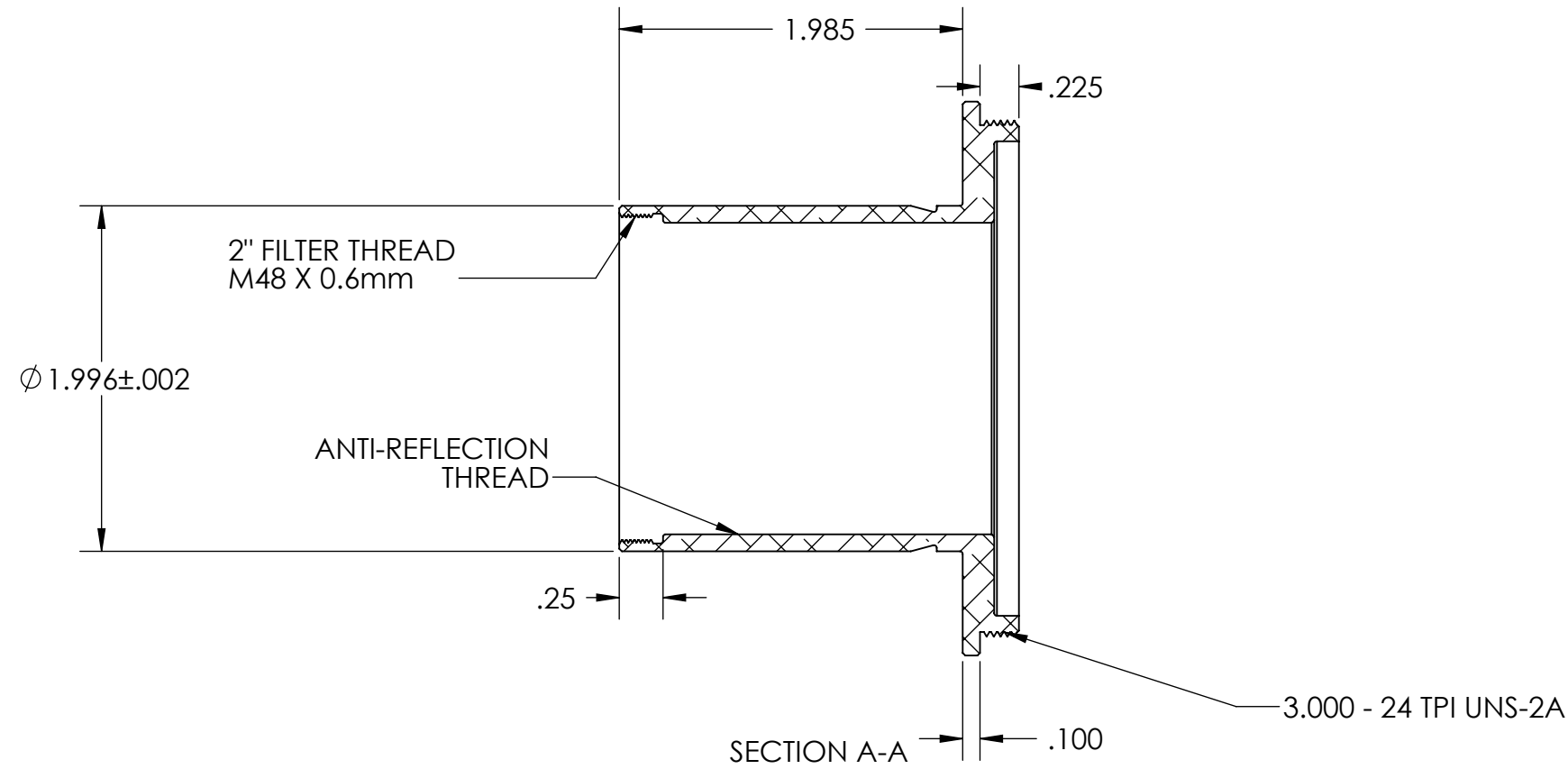
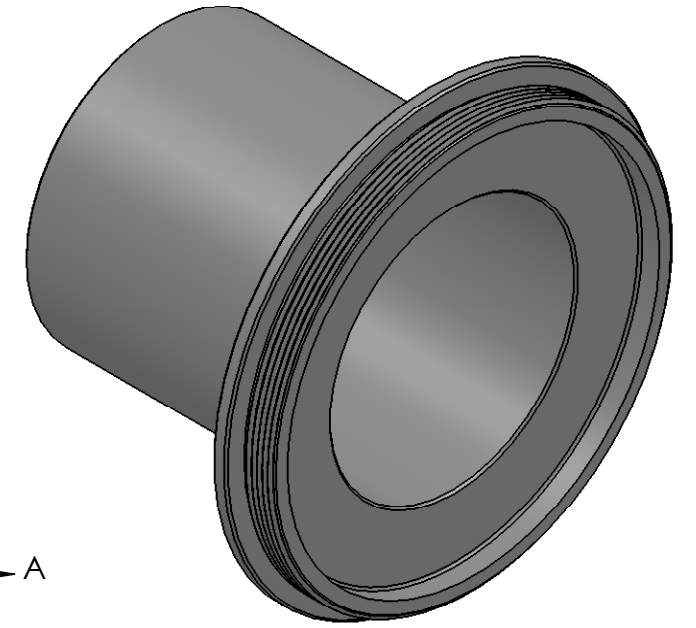

UNLESS OTHERWISE SPECIFIED: DIMENSIONS ARE IN INCHES TOLERANCES: FRACTIONAL ± ANGULAR: MACH ± BEND ± TWO PLACE DECIMAL ±.007 THREE PLACE DECIMAL ±.003	DRAWN	NAME	DATE	<b>Optec. Inc.</b>
	CHECKED	LD	03/30/09	
	ENG APPR.			
	MFG APPR.			
MATERIAL	CONTRACT			TITLE:
FINISH	2-INCH ADAPTERS			2" BARREL TO 3" - 24 TPI
DO NOT SCALE DRAWING	SIZE	DWG. NO.		
	<b>B</b>	17-06333		
	SCALE: 1:1	WEIGHT:	SHEET 1 OF 1	