

STK NO 17654

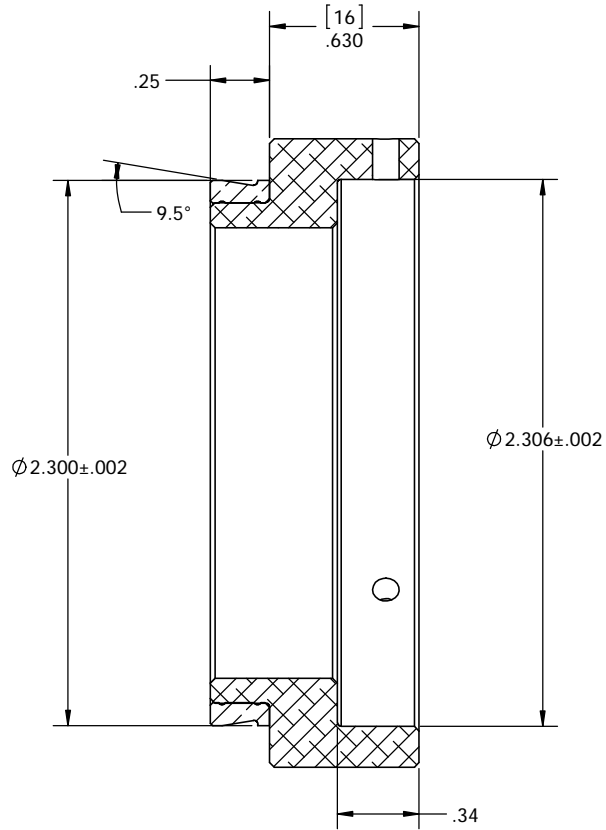

SECTION A-A

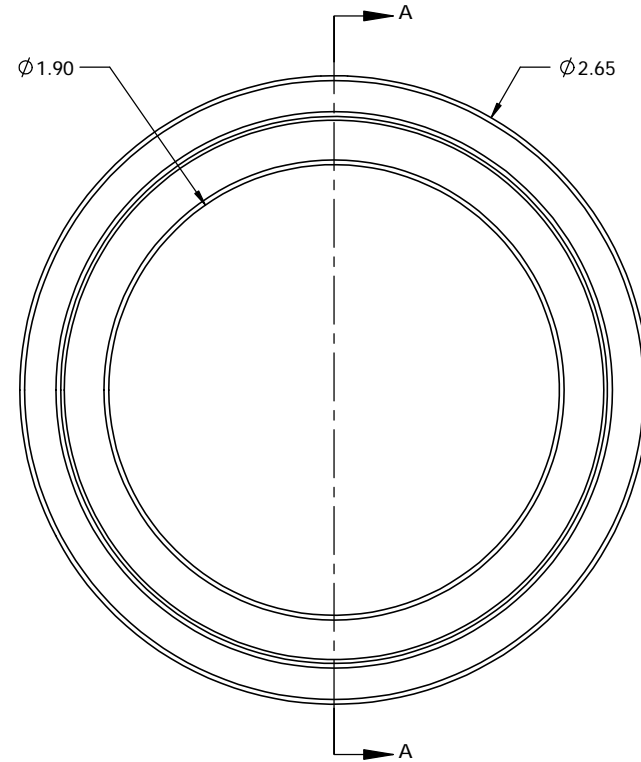

UNLESS OTHERWISE SPECIFIED:		DRAWN	NAME	DATE	<b>Optec Inc.</b> TITLE: 16mm EXTENDER
DIMENSIONS ARE IN INCHES		CHECKED	LD	5/9/14	
TWO PLACE DECIMAL ±.007		ENG APPR.			
THREE PLACE DECIMAL ±.003		MFG APPR.			
MATERIAL		CONTRACT			SIZE
N/A		OPTEC 2300			DWG. NO.
FINISH					<b>B</b>
DO NOT SCALE DRAWING					SCALE: 2:1
					WEIGHT:
					SHEET 1 OF 1

