

PN 5262
 STK NO 19888

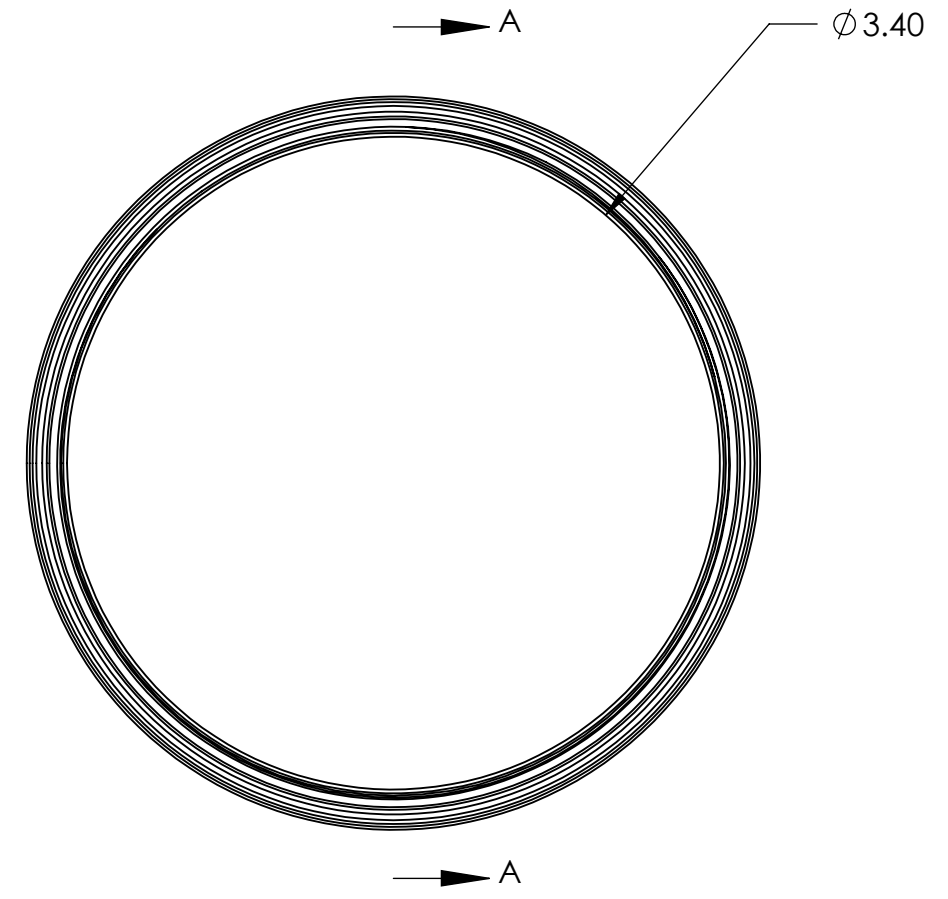
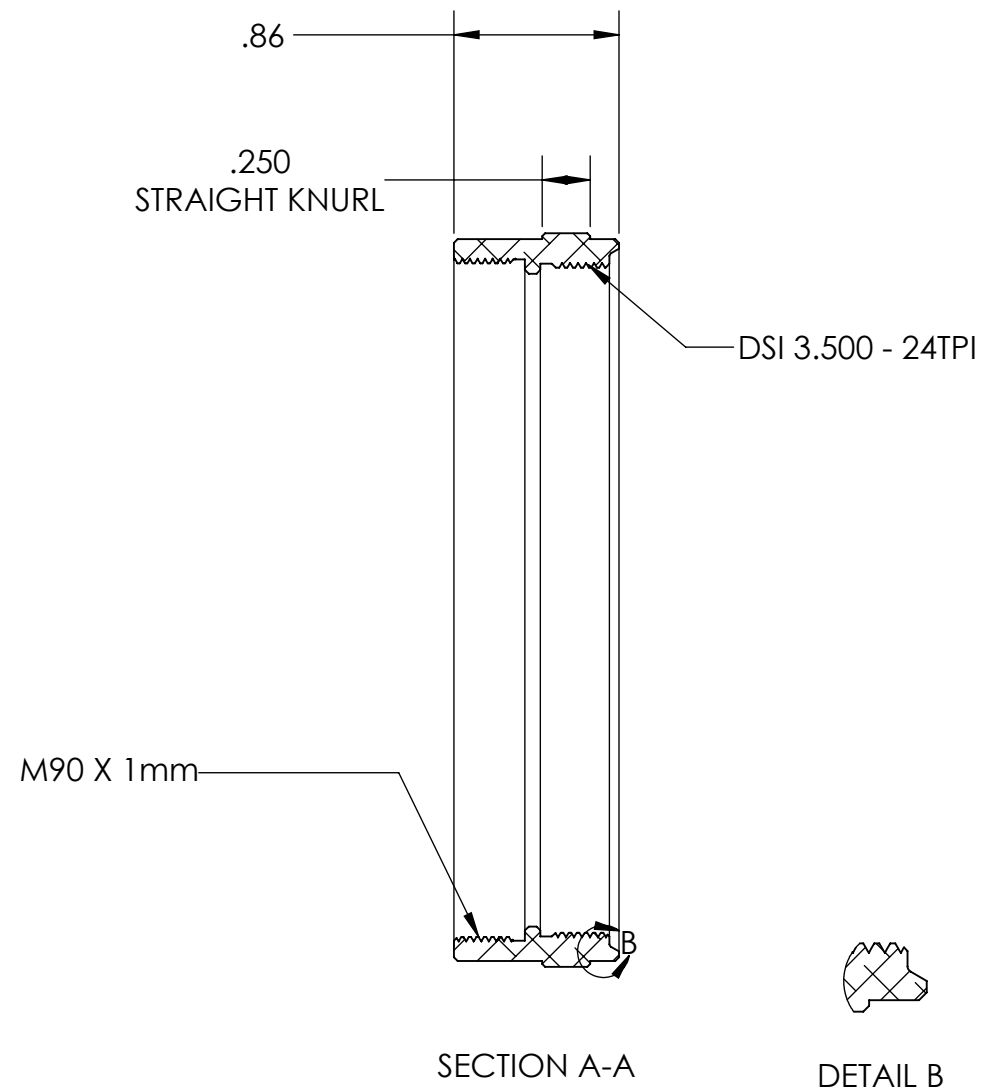

UNLESS OTHERWISE SPECIFIED: DIMENSIONS ARE IN INCHES TOLERANCES: FRACTIONAL \pm ANGULAR: MACH \pm BEND \pm TWO PLACE DECIMAL $\pm .007$ THREE PLACE DECIMAL $\pm .003$	DRAWN	NAME	DATE	Optec Inc. TITLE: M90 X 1mm TO DSI	
	CHECKED	LD	05/19/11		
	ENG APPR.				
	MFG APPR.				
	Q.A.				
THIRD ANGLE PROJECTION 	MATERIAL	CONTRACT DSI SPACERS		SIZE	DWG. NO.
FINISH	6061-T6			B	19-06778
DO NOT SCALE DRAWING	SEE NOTES			SCALE: 1:1	WEIGHT: